

# **IoT business model and Nuvoton Processors**

**SunASIC Technologies Inc.  
June/2023**

# Background

---

September 2016 - Softbank acquired ARM, the leader of mobile architecture, targeting the future IoT growth.

# Challenges to IoT growth

---

- It's a highly diverse market.
- Large organizations lack of “killer application” to justify development cost.
- Small organizations lack of resource to deal with highly sophisticated technical issues such as connectivity, security, etc.
- Cloud IoT infrastructures are there, we need an efficient way to develop massive end nodes.

# The solution to IoT success

---

- Using the Trustzone architecture to protect software IP as well as user data
- **Incremental** firmware development
- Providing custom made MCU with pre-installed software IPs to application developers

# How we can do it?

---

The diverse IoT market can be addressed more efficiently in the same way we are doing for the personal security market.

# The first one to deliver working sample of Cortex-M23

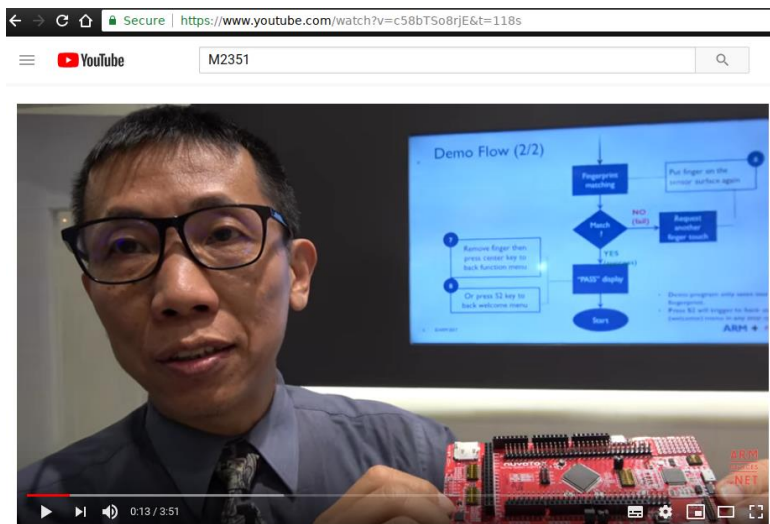

World's first ARM Cortex-M23 in Nuvoton M2351

Nuvoton M2351 is a secure micro controller platform powered by ARM Cortex-M23 core with ARMv8-M architecture, TrustZone technology, security technologies, peripherals and tools. The ultra-low-power 32-bit microcontroller works in low voltage range from 1.62V to 3.6V and can operate at up to 60 MHz frequency, with up to 512 Kbytes embedded Flash memory in dual bank mode supporting OTA firmware update and up to 96 Kbytes embedded SRAM. It is suitable for applications such as IoT secure connections, fingerprint authentication, EMV card reader, security alarm system, smart home appliance, wireless sensor node device (WSND), auto meter reading (AMR) and portable wireless data collector.

## In March 2017 SunASIC demonstrated the 1st M2351 with fingerprint at Embedded World.

# What is our strategy?

---

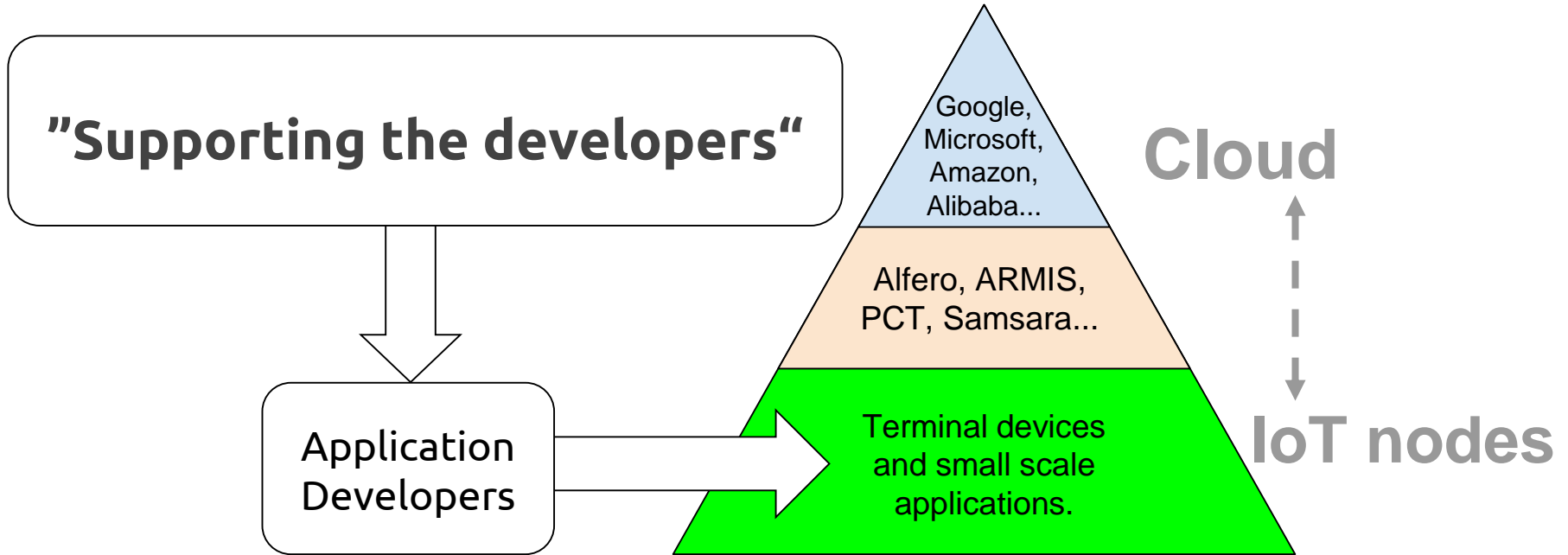

# The use of portable security devices

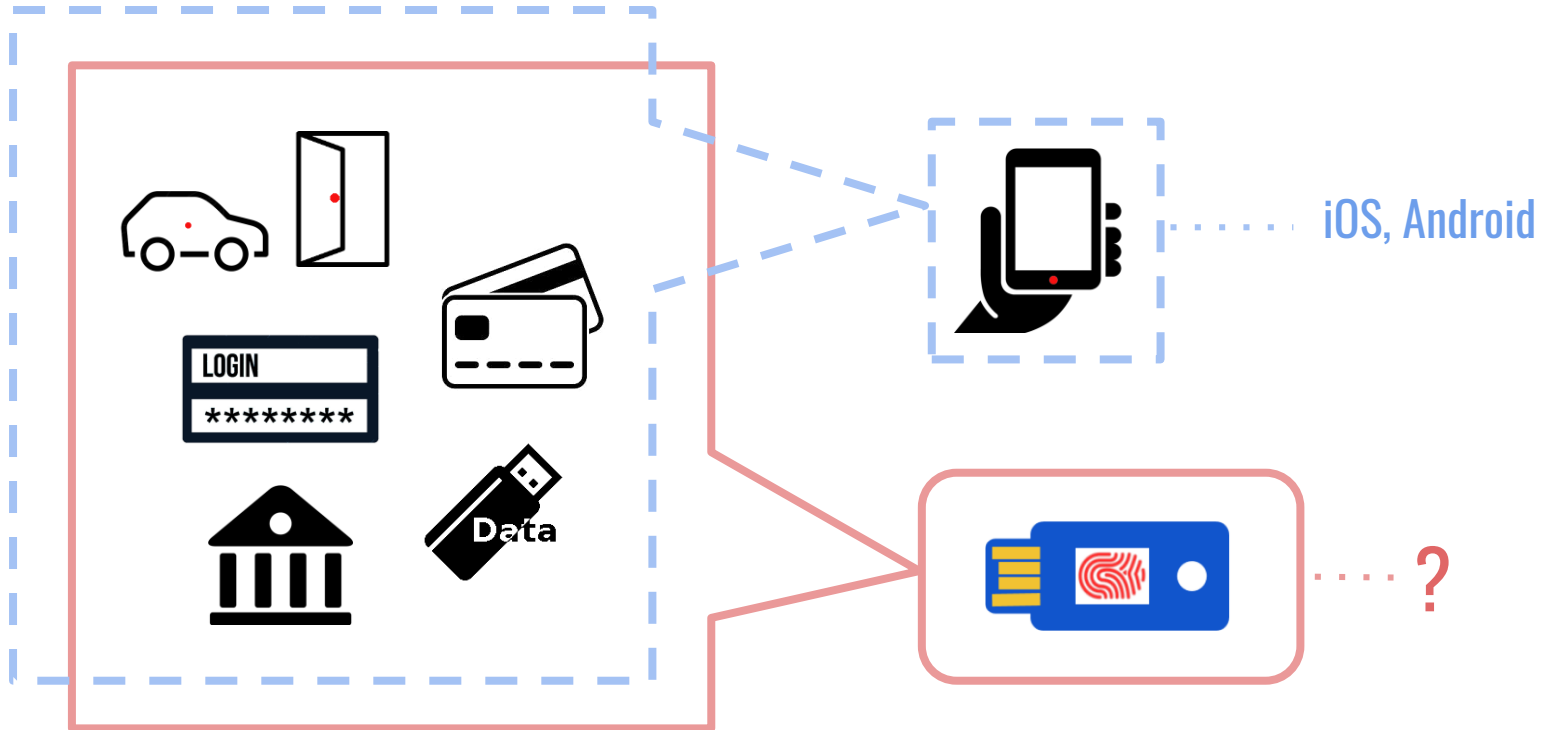



# A New Architecture and Ecosystem for Personal Security

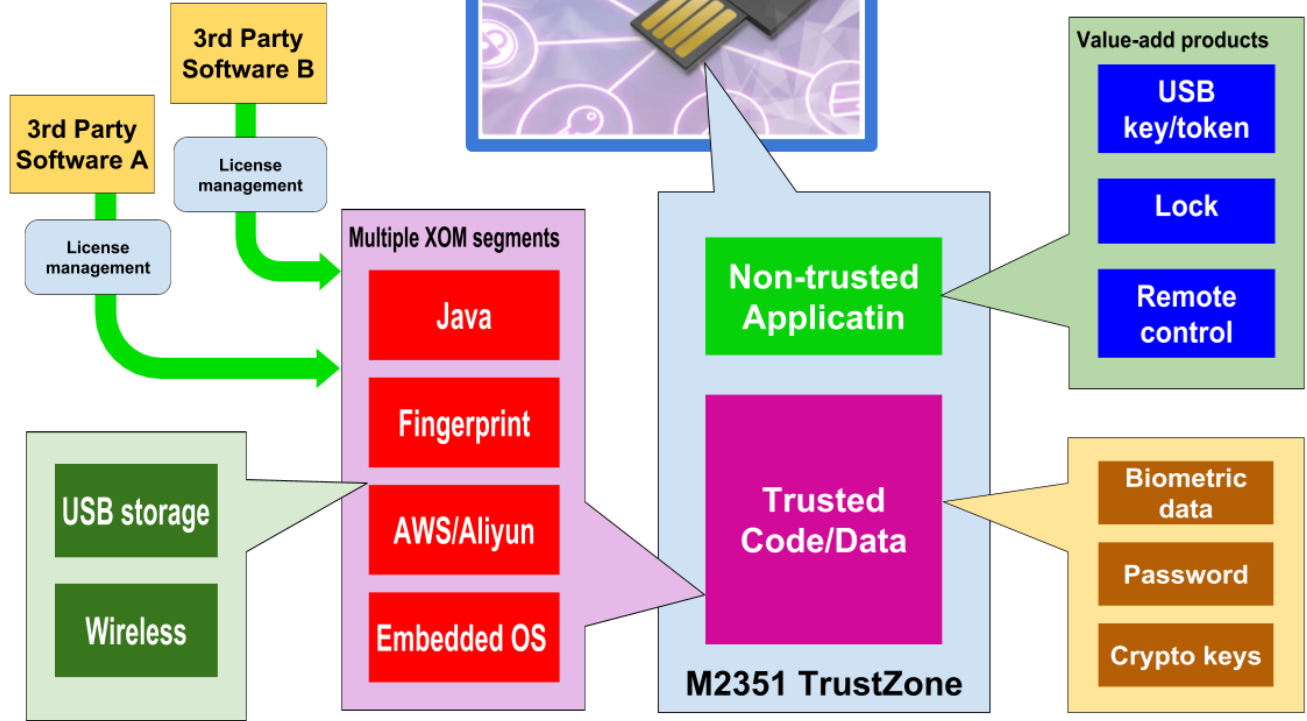

# Our Vision: An E-Store for IoT customization

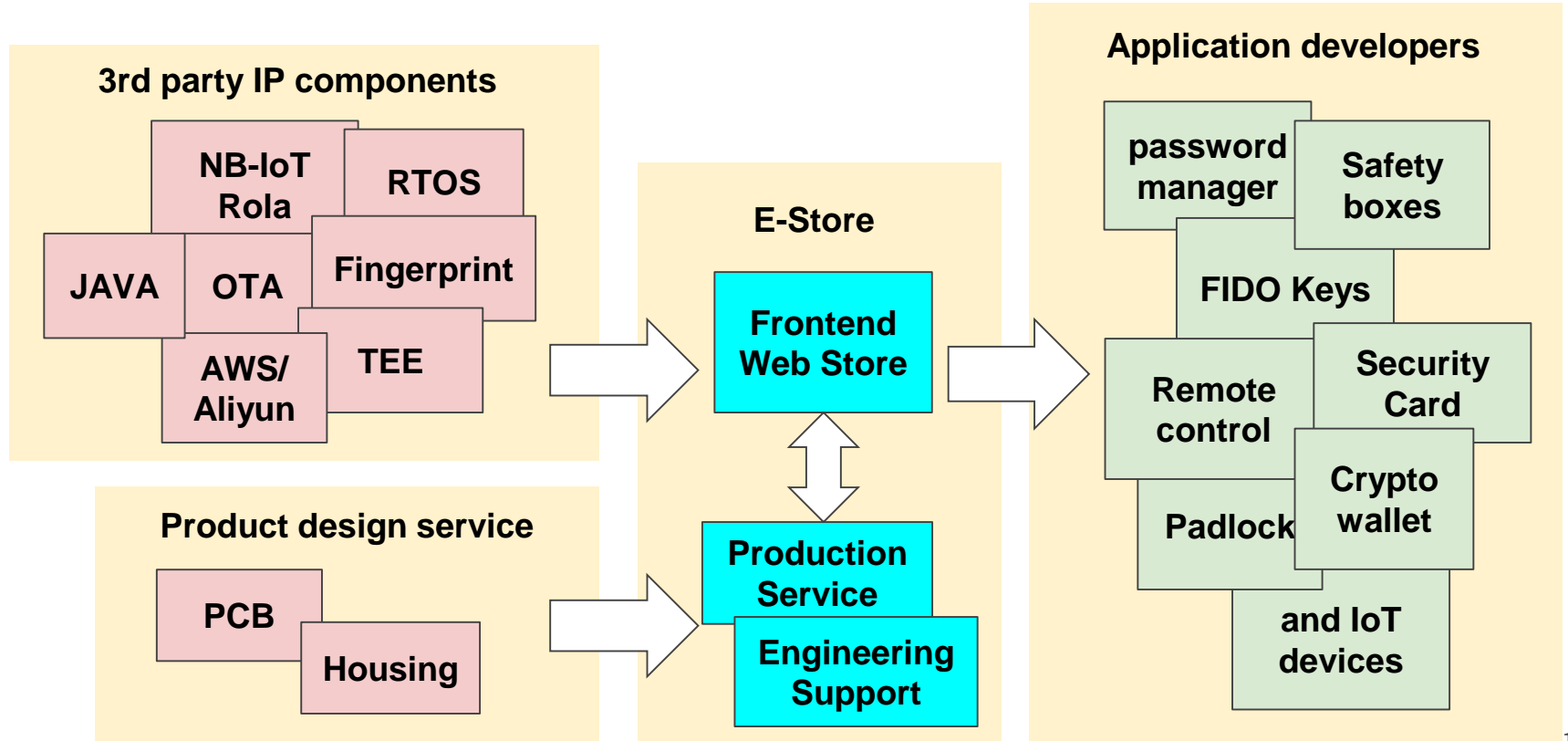

# Incremental firmware integration

---

- A new product development model
- Based on the ARM Cortex-M23/M33 “TrustZone” technology
- Providing protection for user data and software IPs
- Allowing firmware **incrementally** added in the microprocessor.
- Providing value-added solution for application developers.

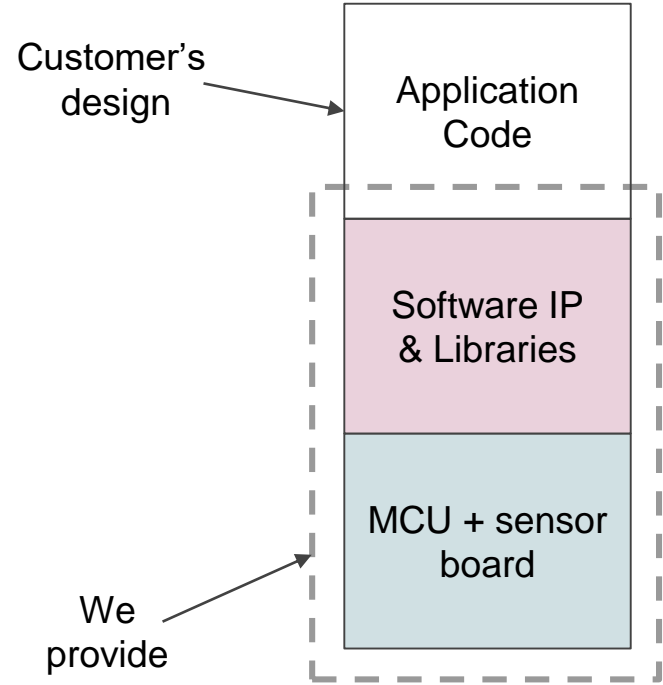

# Advantages of the incremental firmware development model

## For software IP vendors

- Safe, trackable code distribution
- Expanded business opportunity and customer base
- Simplified customer support



## For product developers

- One-stop shopping experience
- Saving NRE fees
- Lower coding/testing cost
- Shorter time-to-market

## Shared resources

- Certified security & connectivity
- Standardization
- Open source projects

# Various security applications with an “open” platform

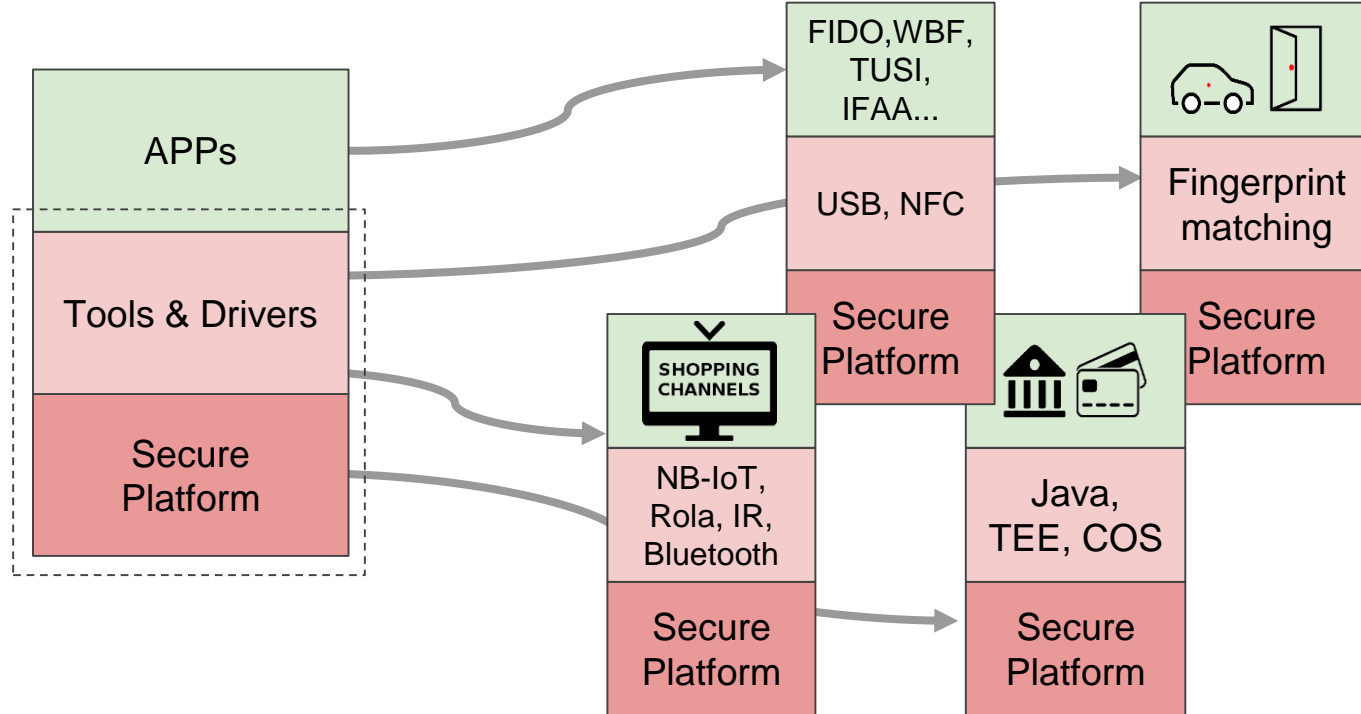

# Cloud + IoT + Security & Authentication

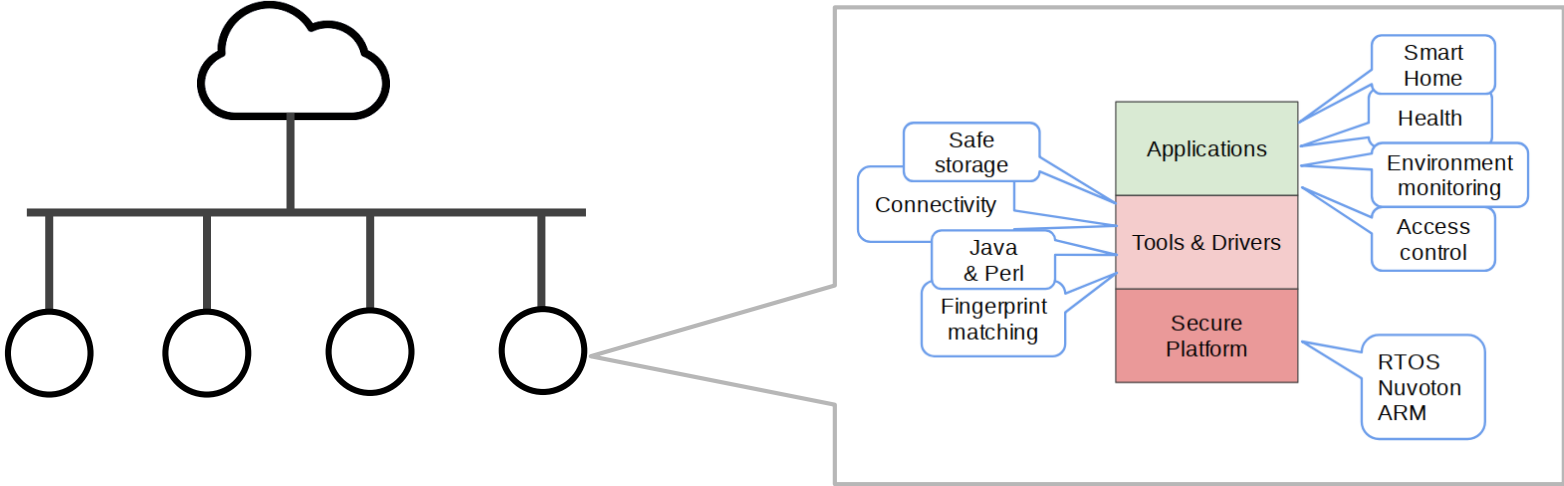

# Requirements / Technical elements

— — —

- Low cost hardware
- Secure execution environment
- Crypto engine for safety of data
- Access management
- Connectivity
- Low power
- Simple API through standardization
- Collaborative development model
- Built to customer's specification

- **TrustZone** - for separating the secure and APP world
- **XOM** - execute-only memory that only allows program execution but not retrieving data
- **Flash Lock** - flags that disables Flash programming.
- **JTAG/ICP** - program debugging under secure environment.

# Personal security products

---

- Standard product lines
  - Fingerprint sensors
  - FC-series fingerprint "buttons"
  - UL-series fingerprint protected USB devices
- Customization services
  - IP acquisition and integration
  - Circuit board design and production
- Goals
  - Flexible production facility
  - Tool building
  - Key IP licensing and distribution

FC1701

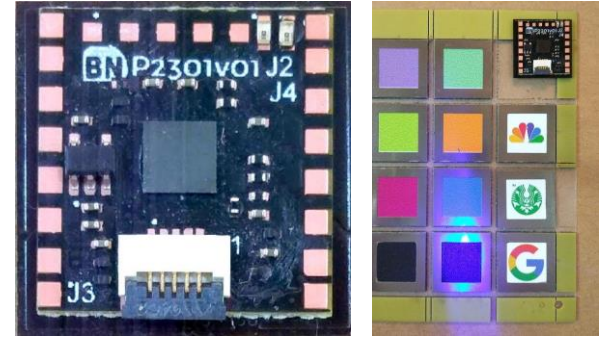

UL1701

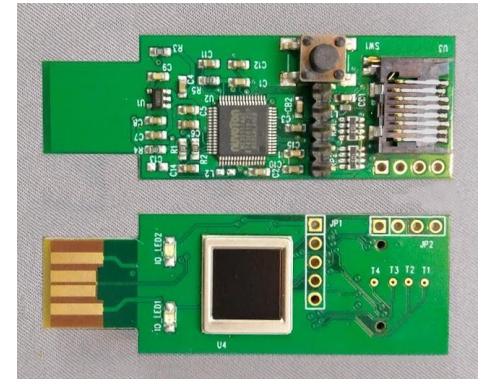



# UL-Series fingerprint module

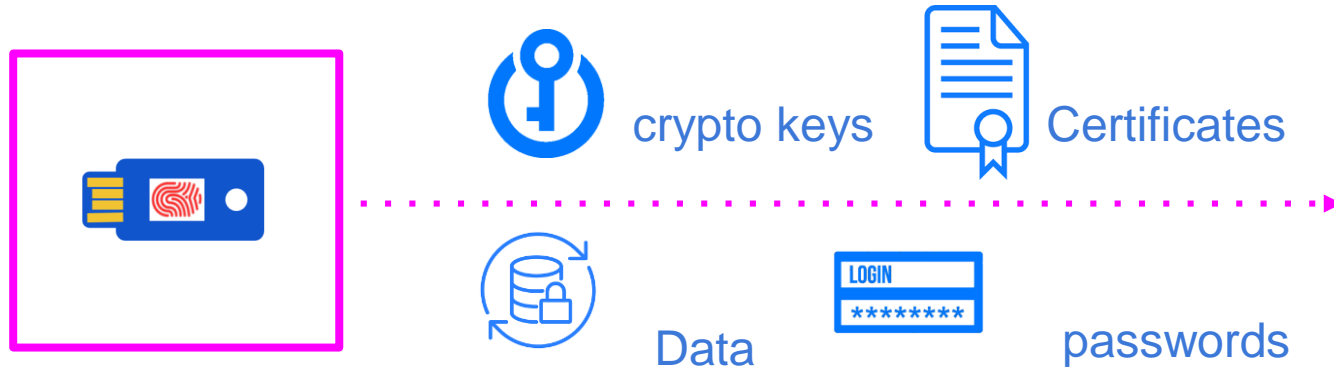

# FC-Series fingerprint “buttons”

---

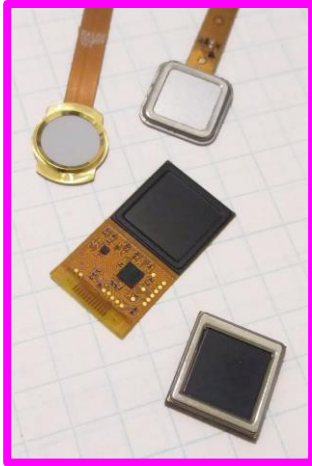

# The supplying network

- E-store - a frontend website
  - Selling custom made microprocessors
  - Engineering support
- R&D team
  - Product design
  - Tool building
  - Standardization
- Production facility
  - flexible and secure content programming
  - Board assembly
- Supplier management
  - IP provider support
  - Contract design and manufacturing

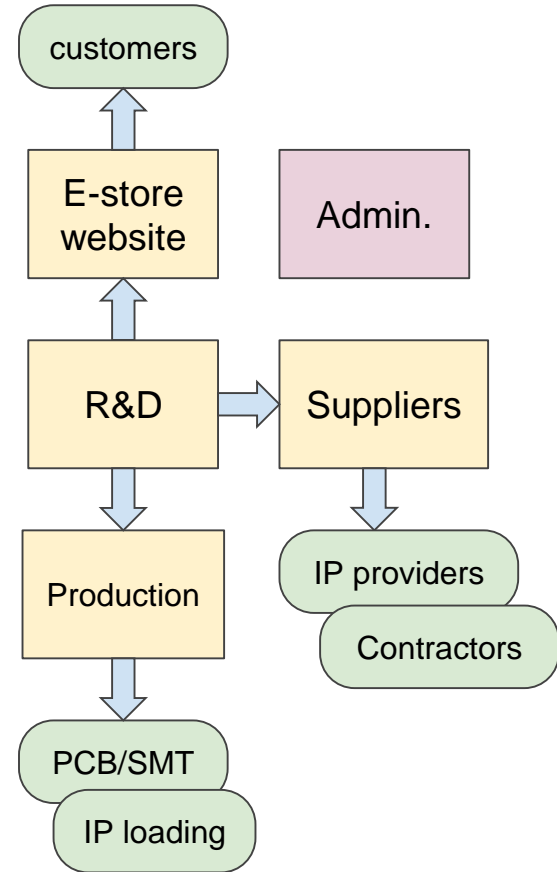

# IoT business network

— — —

- **Expanding IP offering**

- Personal/home/business security
- RTOS, scripting and Connectivity
- Tool and OTA - Remote installation and management for IoT devices

- **Target market**

- Personal security accessories
- Smart home IoT
- Industrial IoT
- Environmental, Agriculture, public utility IoT

# Customer segments

---

- Market segments :

- Automotive network
- Public service -

utility /

- surveillance
- Smart home
- Smart appliances
- Smart community

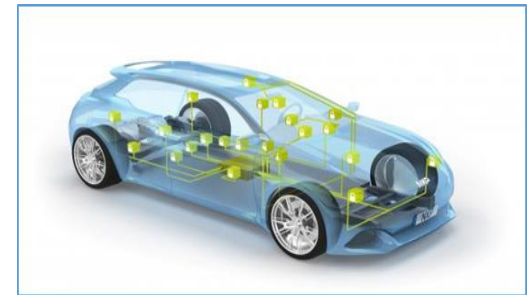

# Value Proposition

---

- Secured IoT networking
- Cloud awareness
- Hardware and software integration service

# Key Activities

- Software standardization and training
- Evaluation board distribution and support
- Module making (SIP/MCP)

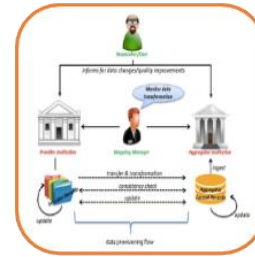

# Key Partners

---

- PCB module making
- SIP packaging house
- Software developers
- Programming / Testing service provider

# Key Resources

- Sales & marketing team
- Engineering team
- Patent

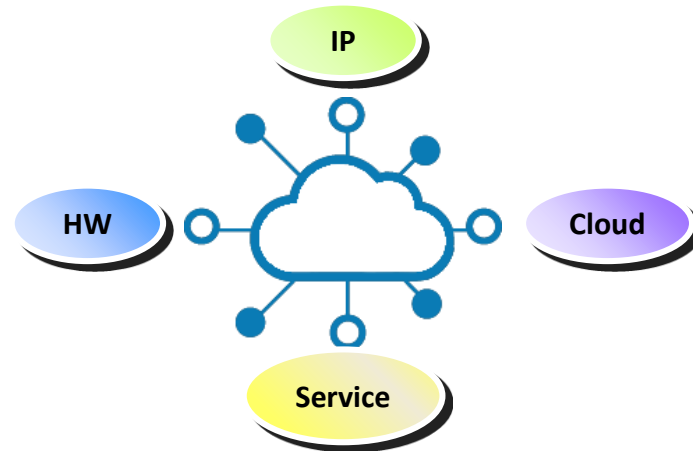

# Customer Relationships

---

- Ecosystem development
- Design and production services

# Channels

- Cloud partners
- Cyber media
- E-Stores

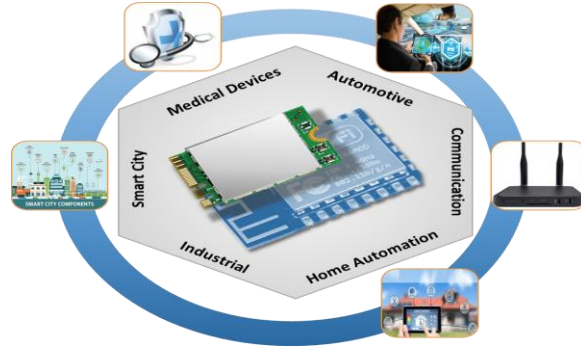



# Cost Structure

---

- R&D
- Sales marketing
- Contracted production

# Revenue Streams

- Personal security products
- IoT security module sales
- NRE based, contracted design and deployment



# Secure IP transport

---

- An “open” platform for developers
- A collaborative development environment
- Provide content protections for security applications
- Integration of multiple functions via incrementally adding components
- Security solutions for IoT
- Pending patent ([US15/869,394](#))

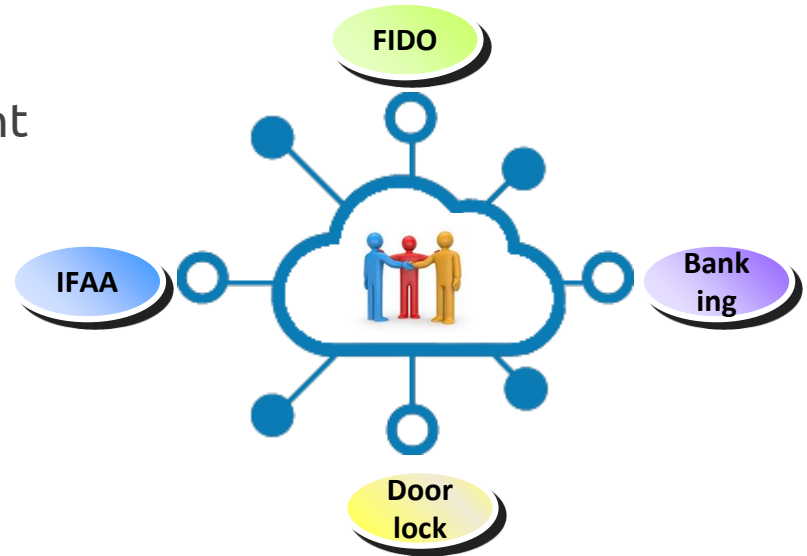

# Portable multi-function security device

---

- A safety box for data
- Function ID + finger ID  $\Rightarrow$  Secret data
  - Crypto key
  - Token
  - Password
  - Personal setting
- Patent [US9690916](#)

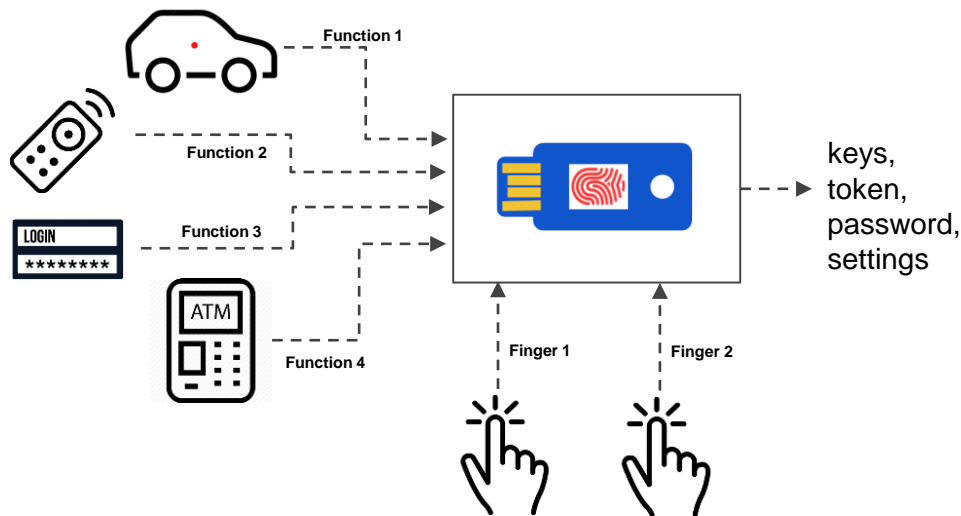

# Simple user interface for managing IoT devices

---

- Using any host computer with a web browser
- No need for OS-dependent driver
- Bidirectional communication implemented through emulating a read-only device
- Patent [US10042947](#)

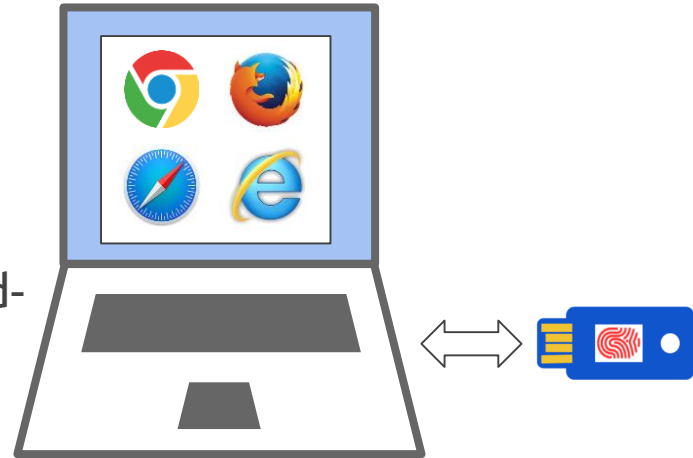

# Our core competence

---

- Top quality fingerprint sensor offered in industry -- image quality, low power and reliability
- Innovative packaging technology
- Secured IP license transport technology
- Patent portfolio covering sensor design, packaging and IoT security

# Fingerprint sensors

Model	Array size	Active area
A122	120x120	6x6 mm <sup>2</sup>
A162	160x160	8x8 mm <sup>2</sup>
A172	176x176	8.8x8.8 mm <sup>2</sup>
A192	192x192	9.6x9.6 mm <sup>2</sup>
A285	288x208	14.4x10.4 mm <sup>2</sup>
A365*	360x256	18x12.8 mm <sup>2</sup>

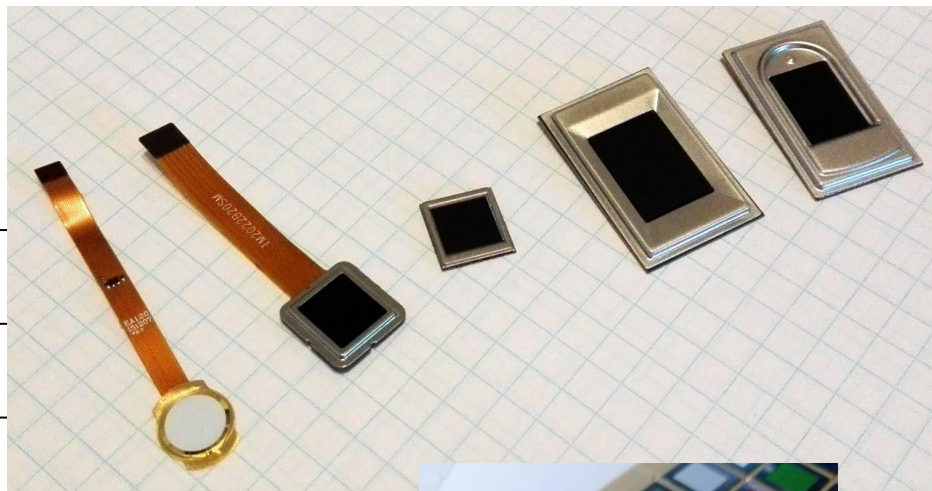

\* FAP10 standard / FBI\_PIV and GA/T certified

# Thank you!

Contact:

Frederick Lin

[fredlin@sunasic.com](mailto:fredlin@sunasic.com)